

# *ROTOPLAT HD/LD*

AUTOMATIC ROTATING TABLE WRAPPING MACHINES

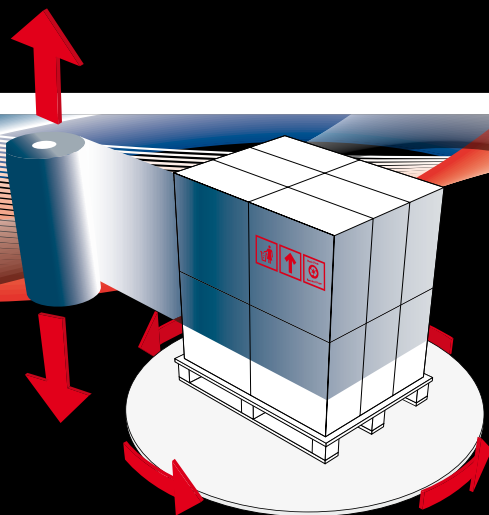

**ROBOPAC**  
SISTEMI

# ROBOPAC SISTEMI

ROBOPAC SISTEMI, established in 1985, is the world leader in the production of systems of fully automatic stretch film wrapping machines for palletized loads. The Company stands out for its great capacity to provide customized and innovative solutions in both performance and reliability. Three technologies have been developed for load packaging: rotating arms, turntables, and rotating rings, in addition to horizontal wrappers for elongated products and packaging systems for the wood industry. Thanks to a worldwide capillary distribution network, and to the spare parts servicing centers present in our foreign affiliates, ROBOPAC SISTEMI ensures quick, decisive after sales service support.

# AETNA GROUP

AETNA GROUP produces and sells on a worldwide basis stretch film wrapping machinery, bundlers, shrink film wrappers, cartoning and taping machines. The Group counts 460 employees of which 80 engaged in the After Sales Department. 94, 000 machines sold and installed worldwide with yearly sales of over 124 million dollars. Four production plants, three of which are in Italy, one in the Republic of San Marino, a joint venture in India, ROBOPAC PERKS, a network of over 460 Agents and Distribution and 5 foreign affiliates located in France, Great Britain, Germany, United States and the new AETNA GROUP VOSTOK in Moscow.

ROBOPAC SISTEMI pursues the Quality policy with commitment and by following this direction in 2003 it has received from TÜV SÜD ITALIA the acknowledgement consequently renewed in 2006 for the adequateness of its organization to the UNI EN ISO 9001:2000.







# ROTOPLAT HD/LD

A complete range of rotating platforms with driven roller surface to wrap and stabilize loads on pallets with stretch film to be used in automatic packaging at the end of the line. Rotoplat series wrapping machines stand out for their driven roller surface rotation system which is made up of a toothed thrust bearing supported by a high load capacity ball bearing and high resistance pin transmission; this construction solution ensures high operating reliability and working life in the most wearing use conditions. Platform rotation speed and relevant acceleration and deceleration ramps are controlled by a frequency converter; this guarantees that the driven roller surface always stops in phase regardless of the load weight and makes sure it is always aligned with the infeed and outfeed conveyors, assuring correct pallet supply and unloading.

Thanks to these characteristics, Rotoplat series wrapping machines find wide application in a variety of merchandise sectors. 2 models are available with the following application characteristics: ROTOPLAT 3000 HD: with maximum 17 RPM rotation speed suited to wrap and move pallets in automatic cycles in merchandise sectors that require high performance. ROTOPLAT 3000 LD: with maximum 12 RPM rotation speed suited to wrap and move pallets in automatic cycle with reduced investment costs. ROBOPAC SISTEMI also provides complete solutions that range from end palletizing line packaging to the shipping and storage warehouse with a complete range of: driven roller, chain, deviator and track transport pallet conveyor systems and stackers and other devices and accessories for load handling.

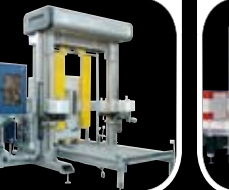

ROBOPAC SISTEMI's production range in packaging with stretch film is based on the following types of machines:

 <b>ROTOPLAT</b>	 <b>HELIX</b>	 <b>GENESIS</b>	 <b>ROBOHOOD</b>	 <b>ROBOBAND</b>	 <b>SPIROR</b>
Automatic turntable wrapping machine	Automatic rotating arm stretch wrapping machines	Vertical rotating ring wrapping machines	Automatic stretch hood machines	Automatic band wrapping machines	Horizontal rotating ring wrapping machines

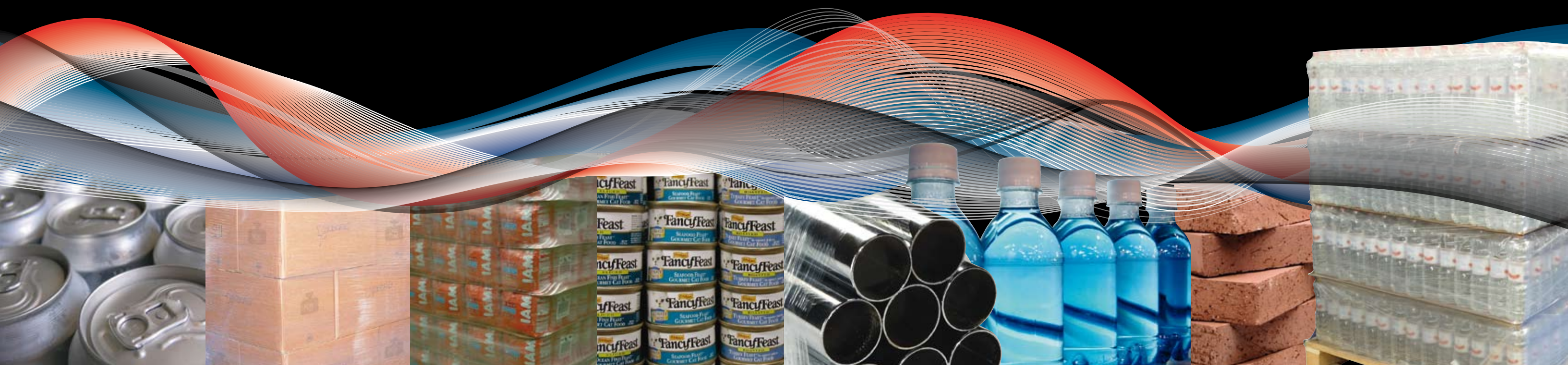

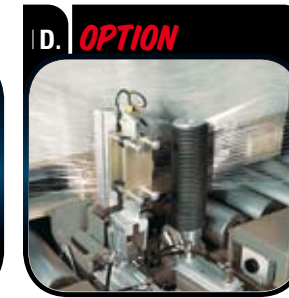
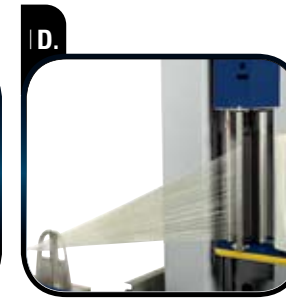
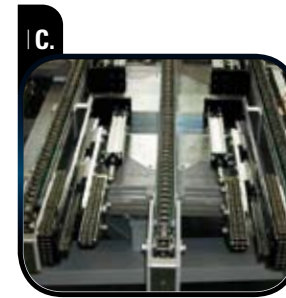
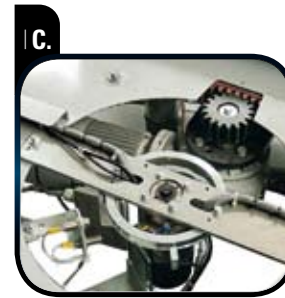
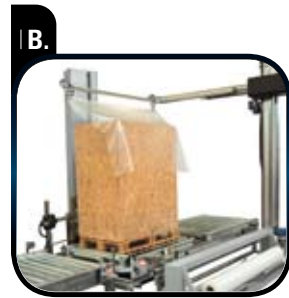

## ROTOPLAT HD

## ROTOPLAT LD

### A. TOP PLATEN DEVICE

Pneumatically/mechanical driven device used as an option with especially unstable loads or in combination with top cover systems (Top Inside).

### B. TOP SHEET COVER

Top device to cover the pallet with polyethylene film.

Film is prepared and cut during the wrapping cycle and machine stop time to position the top are reduced to a minimum. Production capacity remains practically unaltered. Equipped with its own support structure, it can be easily installed on wrapping lines. The reduced dimensions facilitate handling and transport. Sturdy and reliable, it easily adapts to different height pallets.

### C. ROTATION UNIT

High resistance toothed wheel kinematics with pin transmission. Rotation speed and acceleration and deceleration ramps controlled by a frequency converter to safeguard transmission part working life and integrity. For pallet loads with bottom slats crosswise to the movement direction, a table is available with chain transport.

### D. CLAMP AND CUT

Newly designed scissor clamp device and cutting unit with built-in welder: high versatility in use with various sized pallets and minimum film tail that perfectly adheres to the pallet. Spring clamp (ROBOPAC patent) with pulse hot wire film cut and film tail pallet welding device option available.



## ROBOPAC PRE-STRETCH UNITS

### TECHNOLOGY AND INNOVATION FOR HIGH PERFORMANCES

The roll carriages installed on the Rotoplat series wrapping machines achieve maximum stretch capacity thanks to the high grip of the material used to cover the pre-stretch rollers, ensuring:

- excellent load stability
- minimum film consumption
- reduced environmental impact

The film deposit strength on the load is controlled by patented electronically controlled compensation systems; these technical solutions can even wrap lightweight, fragile and soft loads without deformations.

Electromagnetic brake carriage on return roller with film elongation values adjustable from control panel available on models ROTOPLAT HD and ROTOPLAT LD.

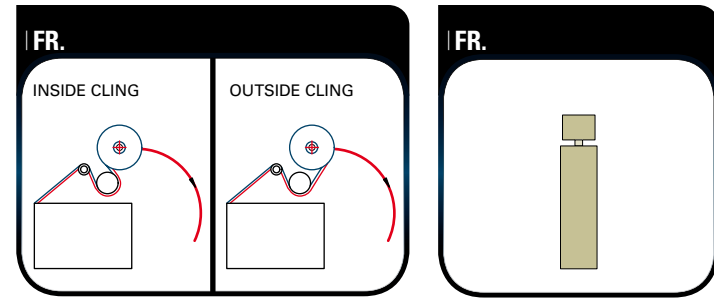

Powered pre-stretch film carriage with fixed gears, 150-200-250%, with possibility for manual adjustment of the wrapping tension. The pre-stretch ratio that can be obtained is easy to modify by manual substitution of the pre-stretch gears.

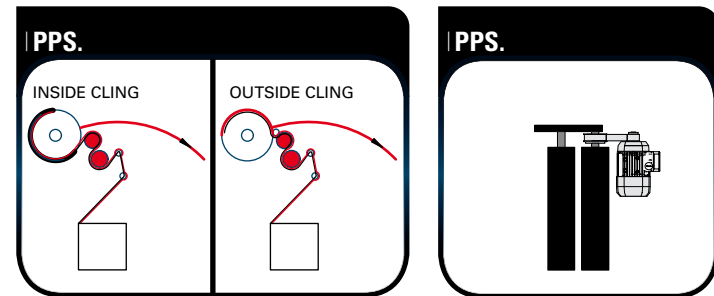

Powered rollers pre-stretch carriage with fixed ratios available on ROTOPLAT HD. Maximum pre-stretch value: 340%; other values available: 80%-150%-190%-225%. Film deposit force onto the load controlled by electronic device.

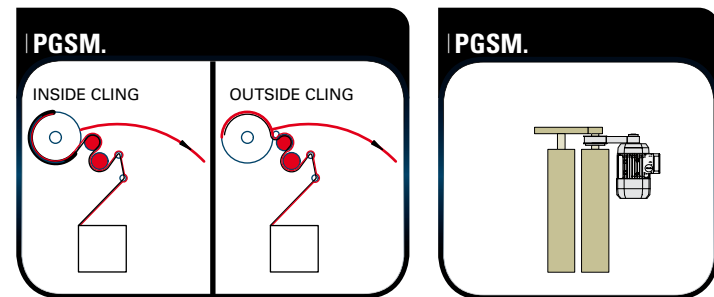

Powered rollers pre-stretch carriage with two independent motors and pre-stretch ratio adjustable from 80% to 400% from control panel available on ROTOPLAT HD. In option, pre-stretch ratio display on control panel. Film deposit force onto the load adjustable from panel and controlled by electronic device.

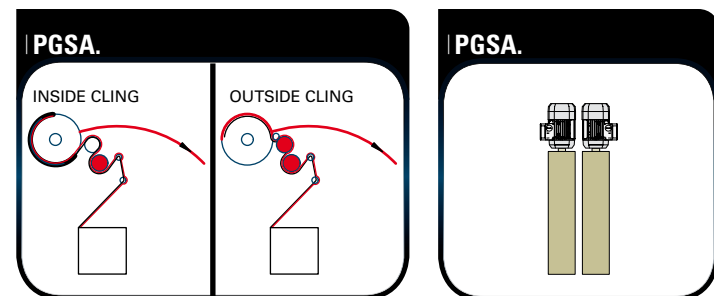

## “ROPING” DEVICE

Device that reduces the film strip into a “rope” to ensure more efficient load stabilization. Film is grouped low/high in the single movement version while it is grouped at the centre in the dual cylinder version.



## TECHNICAL FEATURES

MACHINES		3000 LD	3000 LD T.I.	3000 HD	3000 HD T.I.
A	inches	41	91	47	93
B	inches	69	69	91	91
C	inches	110	159	138	183
D	inches	272	272	268	268
E	inches	99	99	99	99
F	inches	73	73	73	73
G	inches	99	99	99	99
H	inches	128	128	129	129
H1	inches	/	161	/	161
P	inches	79	79	79	79
T	inches	20	20	20	20
Pallet dimensions (*)	inches	47x39	47x39	47x39	47x39
Table speed	Rpm	12	12	17	17
Standard power supply	V/Hz	400/50	400/50	400/50	400/50
Power installed	Kw	3.5	5.5	4	6
Air pressure	Bar	6±1	6±1	6±1	6±1
Air consumption	NI/min	350	350	350	350

(\*) POSSIBILITY OF STRETCH WRAPPING HALF AND QUARTER PALLET. / T.I. Top Inside

## ROTOPLAT HD - HD T.I.

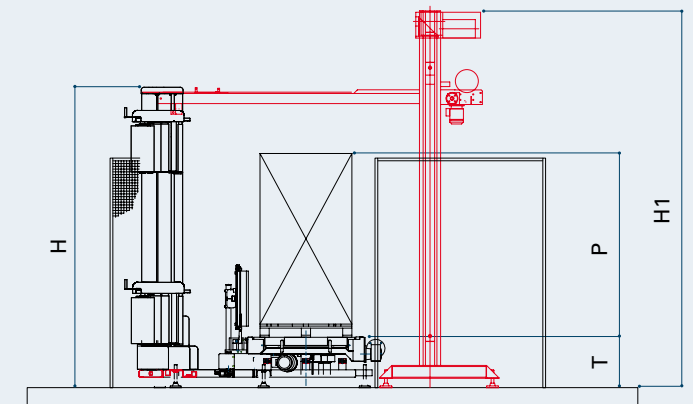
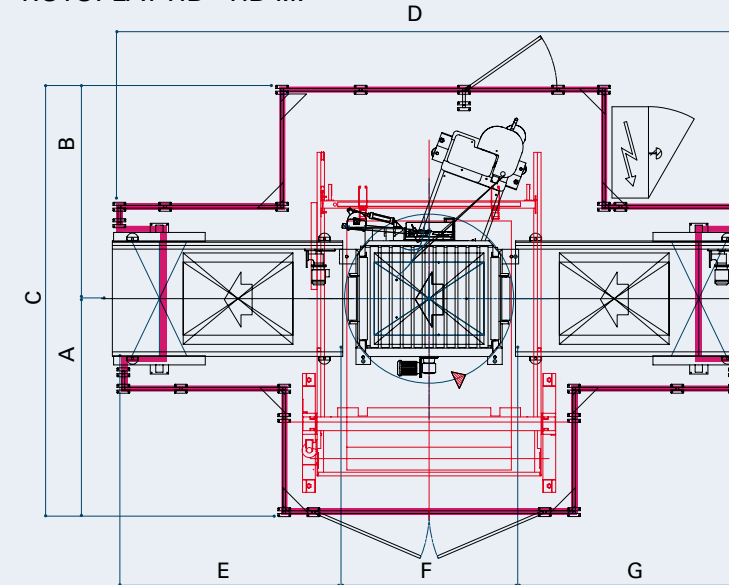

## ROTOPLAT LD - LD T.I.

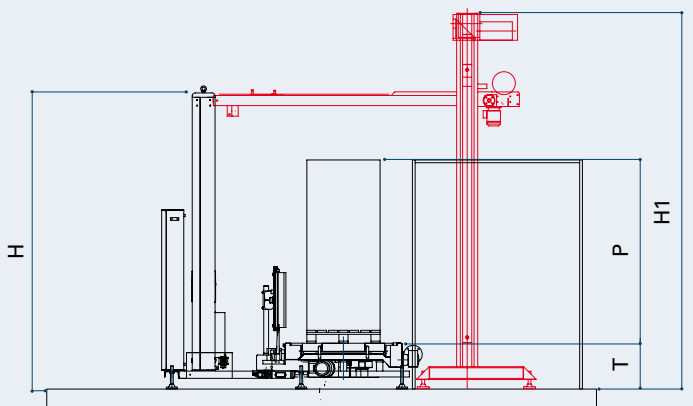
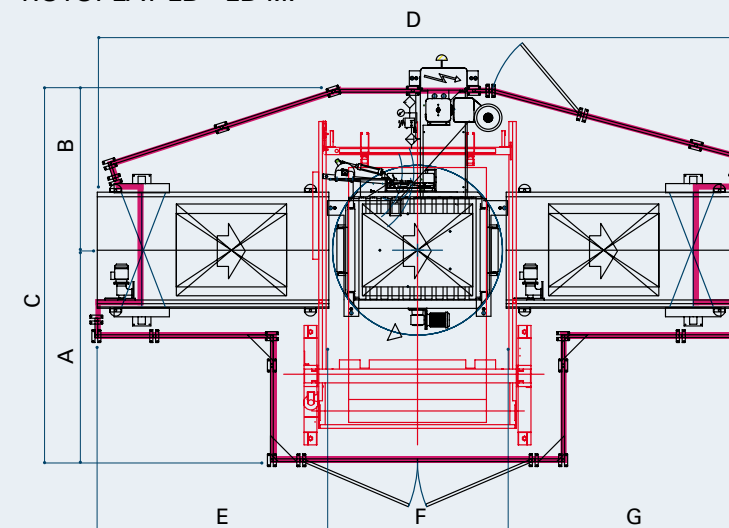

PERIMETRAL GUARDS ACCORDING TO CE WITH SAFETY PHOTOCELLS BARRIERS. TECHNICAL SPECIFICATIONS MAY VARY WITHOUT PRIOR NOTICE.

*We pack your business!*  
www.aetnagroup.com

**AETNA GROUP U.S.A. Inc.**

2475B Satellite Blvd. - Duluth - GA 30096-5805 - USA  
phone (+1) 678 473 7896 - toll free (866) 713 7286 - fax (+1) 678 473 1025  
aetnagroup@aetnagroupusa.com

**ROBOPAC SA**

Strada Rovereta, 27 - 47891 Falciano - Repubblica di San Marino  
tel. (+378) 0549 910511 - fax (+378) 0549 908549/905946  
ropobac@aetnagroup.com

**AETNA GROUP SPA - ROBOPAC SISTEMI DIVISION**

S.S. Marecchia, 59 - 47827 Villa Verucchio - Rimini  
tel. (+39) 0541 673411 - fax (+39) 0541 679576  
ropobacsistemi@aetnagroup.com

**AETNA GROUP SPA - DIMAC DIVISION**

Via Rinascita, 25 - 40064 Ozzano Emilia - Bologna  
tel. (+39) 051 791611 - fax (+39) 051 6511013  
dimac@aetnagroup.com

Via Villanova, 305 - 61010 Pietracuta di San Leo - Pesaro Urbino  
tel. (+39) 0541 671131 - fax (+39) 0541 679576  
pentatec@aetnagroup.com

**AETNA GROUP UK LTD**

**Packaging Heights**

Highfield Parc - Oakley - Bedford MK43 7TA - England  
tel. (+44) 0 1234 825050 - fax (+44) 0 1234 827070  
sales@aetna.co.uk

**AETNA GROUP FRANCE S.a.r.l.**

4, Avenue de l'Europe - 69150 Décines - France  
tél. (+33) 04 72 14 54 01 - télécopie (+33) 04 72 14 54 19  
commercial@aetnafr.aetnagroup.com

**AETNA GROUP DEUTSCHLAND GmbH**

Liebigstr. 6 - 71229 Leonberg - Höfingen - Germany  
tel. (+49) 0 7152 33 111 30 - fax (+49) 0 7152 33 111 40  
info@aetna-deutschland.de

**ROBOPAC PERKS MACHINERY (I) PVT. LTD.**

Khyati Industrial Estate, Plot B/7 - unit No. 115/116 - Laxmi Nagar  
Goregaon (W) - Mumbai - 400 900 - India  
tel. (+91) 022 878 2281 - fax (+91) 022 874 6173  
perkengineering@vsnl.com

**AETNAGROUP**  
USA 